

A U S T R A L I A

RoboCup Junior Australia

Rescue Line Rules 2022

Last Modified: 7 February 2022





RoboCup Junior Australia Executive Committee

President	Evan Bailey (Victoria)
Vice President	Karen Binns (New South Wales)
Minutes Secretary	Brenda Gahan (Queensland)
Treasurer	Wilson Cheng (New South Wales)
Secretary	Steven Lau (Queensland)

RoboCup Junior Australia Rescue Technical Committee

Chair	David Ebert (Victoria)
Members	David Musgrave (Western Australia) Nick Barkley (Queensland) Graham Stock (Australian Capital Territory) Karen Binns (New South Wales) Ashley Kasper (New South Wales) Jason Flood (New South Wales) Colin Becker (South Australia) Michael Russo (South Australia) Evan Bailey (Victoria)

Code of Conduct

Spirit

It is expected that all participants, students and mentors, will respect the aims and ideals of RoboCup Junior as set out in our mission statement. In turn, the volunteers, referees and officials will act within the spirit of the event to ensure the event is competitive, fair and most importantly fun. "It is not whether you win or lose, but how much you learn that counts."

Sharing

It is the overall desire of RoboCup Junior events, that any technological and curricular developments will be shared with other participants after the events. Any developments including new technology and software examples may be published on the RoboCup Junior website after the event, furthering the mission of RoboCup Junior as an educational initiative. Participants are strongly encouraged to ask questions of their fellow competitors to foster a culture of curiosity and exploration in the fields of science and technology.

Local Variations

These rules will be in use for the RoboCup Junior Australia Australian Open for the titled year. State and Regional events may implement variations of these rules. These variations will be communicated to the participants through email and/or on the relevant State Webpage on the RoboCup Junior Australia website prior to the state or regional event.

Notes/Advice vs. Rules

This document includes notes/advice to the competitors and mentors, plus rules that are firm. This has been done to remove ambiguity. There is a notation to indicate whether the content of this document is to be read as a note/advice or as a rule. **Notes/advice appear in green.**



Table of Contents

1 The Challenge	5
1.1 The Scenario	5
2 Playing Field.....	6
2.1 Tiles.....	6
2.2 Lines	7
2.3 Markers.....	7
2.4 Speed Bumps, Debris and Obstacles	8
2.5 Ramps and Elevated Tiles	8
2.6 Doorways	8
2.7 Chemical Spills	9
2.8 Start Tiles	9
2.9 Rescue Capsule	9
2.10 Game Zone.....	10
3 Robot	10
3.1 Robot Configuration	10
3.2 Robot Control	10
3.3 Inspection	11
3.4 Violations	11
4 Inspection	11
4.1 Electronic Submission	11
4.2 Interviews	11
4.3 Journal/Log Book	11
4.4 Journal/Log Book Criteria	12
5 Teams	12
5.1 Definition	12
6 Game Play.....	13
6.1 Length of a Game.....	13
6.2 Pre Game	14
6.3 Game Play	14
6.4 Lack of Progress	15
6.5 Following the Line.....	16
6.6 Scoring	17
6.7 Preliminary Rounds.....	17



6.8	Finals.....	18
6.9	Special Circumstances.....	18
7	Challenge Track	18
7.1	Challenge Description	18
7.2	Scoring the Challenge	19
7.3	Example Challenges	20
8	Conflict Resolution	21
8.1	Referee and Referee Assistant.....	21
8.2	Rule Clarification.....	21
8.3	Special Circumstances.....	21
9	Code of Conduct	21
9.1	Spirit.....	21
9.2	Fair Play.....	21
9.3	Behaviour.....	21
9.4	Mentors	22
9.5	Ethics and Integrity	22
9.6	Sharing	23



1 The Challenge

1.1 The Scenario

1.1.1 A terrible disaster has hit the city and caused a large chemical storage unit to rupture spilling thousands of litres of toxic chemicals in the centre of the city. There is a Victim trapped in a sinking Rescue Capsule in the chemical spill. Rescue crews are having trouble entering the city with the amount of rubble around, and rescue from the air has also been ruled out due to the noxious gases rising from the toxic chemicals directly above the spill. It has been decided that the best form of rescue is the deployment of an autonomous robot that can navigate to the chemical spill, rescue the victim, and exit the chemical spill.

Your team has been asked to design, make, and appraise a robot to complete this challenge.

The robot can be deployed at the start tile (City Limits) or air dropped to any designated tile that is at least two tiles away from the chemical spill (Drop Zone).

1.1.2 Rile Rover Rescue: The robot must navigate to the scene, find, and then rescue the Victim by pushing or dragging the Rescue Capsule out of the chemical spill.

Riley Rover Rescue is a new division in the rules for 2022. The aim is to create a very accessible entry point for students who are entirely new to robotics or are attempting a new challenge such as creating a robot using an Arduino or Raspberry Pi based controller and text-based coding. Students will only be allowed to enter at this division for one year and should be guided to a more complex division by their mentor as capability increases throughout the year as appropriate.

1.1.3 Primary Rescue Line: The robot must navigate to the scene, find and then rescue the Victim by pushing or dragging the Rescue Capsule out of the chemical spill. The robot must then save itself by exiting the chemical spill via the 'Spill Access Point'.

1.1.4 Secondary Rescue Line: The robot must navigate to the chemical spill and then rescue the Victim by first controlling the Rescue Capsule and then manoeuvring and leaving it outside of the chemical spill in its original orientation. The robot must then save itself by exiting the chemical spill via the 'Spill Access Point'.

1.1.5 Open Rescue Line: The robot must navigate to the chemical spill and remove the correct Rescue Capsule from the chemical spill and place it in its original orientation safely on the Evacuation Platform for later collection by an aircrew. The robot must then save itself by exiting the chemical spill via the 'Spill Access Point'. The spill may contain one or more Rescue Capsules - Rescue Capsules with a Victim are silver and empty Rescue Capsules with no Victim are black. Rescuing the Victim will earn the team points for a successful control and rescue. Rescuing an empty rescue capsule will not earn the team points for control or rescue.

1.1.6 Teams will compete in a number of Preliminary Rounds which culminate in a final Head-to-Head Round where the top three teams will be awarded first, second and third place as a result of them demonstrating the best solutions to the challenges according to the rules.

1.1.7 At the discretion of the Chief Judge, more or fewer teams may be taken to the final Head-to-Head Round.



2 Playing Field

All measurements in the rules have a tolerance of 5%.

2.1 Tiles

2.1.1 Tiles will fall into one of seven pools, as described in the table below:

Pool Name	Tile Characteristics
Base Pool	Tiles that consist of continuous black lines with white background
Physical Pool 1	Inclines not to exceed 10° from the horizontal (the Bridge Tile has an incline of less than 7.6°, and a 594 mm ramp raised 90 mm has an incline of 8.7°)
Physical Pool 2	Inclines greater than 10° (e.g., See-saw, ramps from 300 mm tiles) Tiles with obstacles, speed bumps or debris
Logical Pool 1	Tiles with intersections marked with green squares
Logical Pool 2	Tiles with discontinuous lines
Logical Pool 3	Tiles that consist of white lines with black background
Challenge Pool	Tiles that do not fit into another pool

2.1.2 Tiles will be selected for each division as in the table below:

	Base Pool	Physical Pool 1	Physical Pool 2	Logical Pool 1	Logical Pool 2	Logical Pool 3	Challenge Pool
Riley Rover Rescue	✓	✓					
Primary Rescue	✓	✓	✓	✓			✓
Secondary Rescue	✓	✓	✓	✓	✓		✓
Open Rescue	✓	✓	✓	✓	✓	✓	✓

The field will consist of tiles, with differing patterns. Tiles may include but are not limited to the designs shown below:

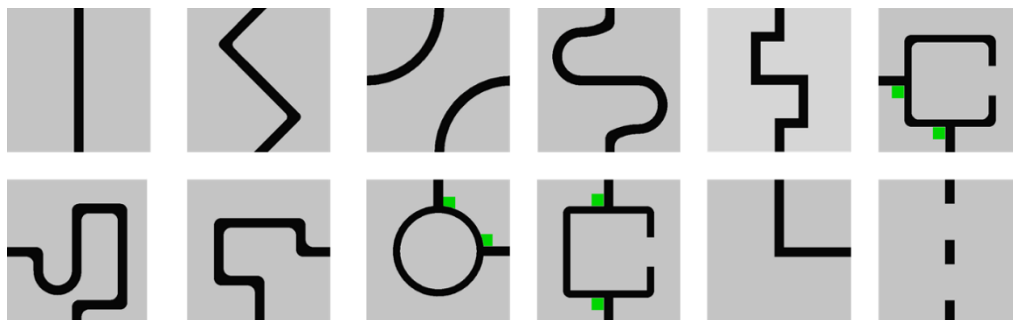

2.1.3 Tiles can be of various sizes with the minimum tile size of 297 mm x 297 mm. Tiles can be any shape or thickness and be made from any material that provides adequate traction for the robot (e.g. melamine, flute board, banner material).

Tiles will typically be either be 'Small Tiles', sized 297 mm x 297 mm or 300 mm x 300 mm, or 'Large Tiles' sized 594 mm x 594 mm. Small Tiles can be printed on A3 paper, and Large Tiles on A2 paper (A2 printing is commonly available at Officeworks). Example Tiles can be downloaded from the Rescue Line page of the RCJA website. Additionally, a Large Tile practise mat, and mounted Small Tile set can be purchased from RCJA Platinum National Sponsor, Modern Teaching Aids (Small Tile set available Q2 2022).



- 2.1.4 Tiles will have a uniform background colour of either black or white allowing the line to be distinguishable from it by common light, colour and vision sensors.
- 2.1.5 There will be a minimum of 4 tiles **in addition to the chemical spill tile** in a Preliminary Round or Head-to-Head Round.
- 2.1.6 The arrangement of tiles may vary between rounds.
- 2.1.7 The top surface of adjacent tiles may differ in height up to 5 mm and be separated by up to 5 mm.
- 2.1.8 The final selection of tiles and their arrangement will not be revealed until the day of the event.

2.2 Lines

- 2.2.1 The line on the tiles will have a width between 15 mm and 20 mm and be a contrasting colour to the background colour of the tile.
- 2.2.2 The line on a tile will be distinguishable from the background colour of the tile by common light, colour and vision sensors.
- 2.2.3 The internal radius of a curved line will be a minimum of 40 mm.
- 2.2.4 The minimum distance from the edge of the tile to the line should be 90 mm. Where this is not the case support material will be added to the field to support the robot.
- 2.2.5 Lines may meet or form an intersection at any angle.

2.3 Markers

- 2.3.1 Intersections markers can be placed anywhere except in the chemical spill.
 - 2.3.1.1 Intersections markers are green and 40 mm x 40 mm in dimension and indicate the suggested path to follow. If no green markers are placed at an intersection, it means it is recommended to continue straight.
 - 2.3.1.2 In the path leading to the Chemical Spill the intersection marker is always placed just before the intersection. See image below for possible cases.

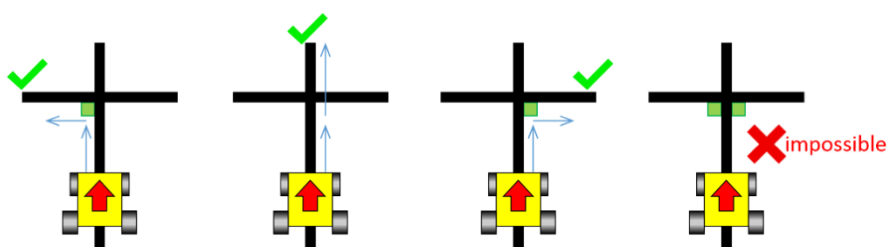

- 2.3.1.3 The colour of markers will be consistent across a single **path leading to the Chemical Spill**.
- 2.3.2 Markers of a colour, with reasonable separation by common light and vision sensors from the tile background colour, may be placed in the field that will trigger behaviours on the robot. **For example, a red marker may be used to make the robot stop moving for 2 seconds.**



2.4 Speed Bumps, Debris and Obstacles

- 2.4.1 Speed bumps have a maximum height of 10 mm. They are a similar colour to the tile's background.
- 2.4.2 Speed bumps will be fixed on the floor. They may be angled.
- 2.4.3 Debris have a maximum height of 3 mm and are not fixed on the floor. They are small materials such as toothpicks, paper, skewers, etc. The reflected colour of the debris cannot be a colour otherwise used on the course.
- 2.4.4 Debris may be spread across the tile.
- 2.4.5 Obstacles may consist of bricks, blocks, weights and other large, heavy items, which provide resistance when pushed or knocked by the robot. Obstacles will be a minimum of 15 cm high and have a base with a maximum diameter or diagonal length of 15 cm.
- 2.4.6 An obstacle may not cover more than one line.
- 2.4.7 A Robot is expected to navigate around obstacles and reacquire the line within 30 cm of the obstacle. Obstacles that are moved in any way will remain where they are moved to, even if it ends up prohibiting the robot from proceeding.

2.5 Ramps and Elevated Tiles

- 2.5.1 Tiles on different levels are connected by ramp tiles. A ramp will not exceed an incline of more than 17.5 degrees from the horizontal surface.
- 2.5.2 Tiles may be elevated off the floor by supporting blocks placed in the corner of the tile. They may only be re-positioned to provide robot clearance by an official.
- 2.5.3 No provision will be made to assist robots that drive off a tile, from getting back on the tile.
- 2.5.4 Tiles may be elevated. Elevation will occur in 90 mm increments.

Rescue Line courses may incorporate 'Tunnels'. Robots, therefore, must be designed so that they can navigate along any tile that may be placed on the base of the 'Tunnel'.

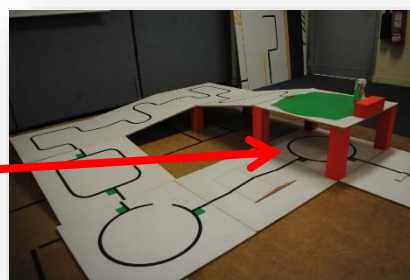

2.6 Doorways

- 2.6.1 The Doorway will:
 - 2.6.1.1 Be 270 mm wide and 270 mm high for Open Rescue Line
 - 2.6.1.2 Be 180 mm wide and 180 mm high for Riley Rover Rescue, Primary Rescue Line and Secondary Rescue Line
- 2.6.2 A doorway may be placed on a straight section of the line with the two uprights approximately equidistant from the line. It will be free standing and not be mounted or taped directly to the tile.
- 2.6.3 If a doorway is present on the course the robot must have passed through it before the score for the round will be recorded (see 3.1.1).

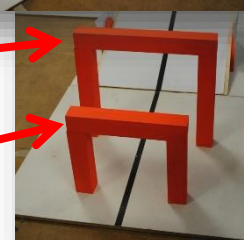

will



2.7 Chemical Spills

- 2.7.1 A Chemical Spill will be green in colour and be distinguishable from the background colour of the tile by common light and vision sensors. It may be any shape and size.
- 2.7.2 At the point where the black line meets a Chemical Spill, there will be a piece of smooth reflective tape (the Spill Access Point) to indicate that the robot is entering the Chemical Spill. The Spill Access Point will have a minimum size of 70 mm x 20 mm.
- 2.7.3 For Open Rescue Line only, Chemical Spills can have one or more Evacuation Platforms located within them. There may be more than one Chemical Spill in a Preliminary Round or Head-to-Head Round. An Evacuation Platform will be a distinguishable colour, a minimum of 200 mm wide, and a minimum height and depth of 70 mm.

2.8 Start Tiles

- 2.8.1 The field can have at most two start locations:
 - 2.8.1.1 City Limits
 - 2.8.1.2 Drop Zone
- 2.8.2 The City Limits tile consists of a lead-in black line and does not count for any points. Robots are to start behind the join between the start tile and the first course tile.
- 2.8.3 A tile may be nominated as a Drop Zone tile as an alternative start location to the City Limits start tile. The Drop Zone tile must be at least two tiles away from the Chemical Spill. Once the game timer has started the Drop Zone cannot be changed (unless a Restart is called). **The nominated Drop Zone can be different for each round.**
- 2.8.4 Either start tile may be used for the start of a round or when starting after a lack of progress is called (see 6.4).
- 2.8.5 A Drop Zone Puck will be a suitable size and colour to be easily identified by the Robot Handler and referees without interfering with the robot.

2.9 Rescue Capsule

- 2.9.1 A Rescue Capsule with a Victim inside will be represented by a standard 375 ml aluminium can, standing upright, wrapped in aluminium foil or aluminium foil tape.
- 2.9.2 The Rescue Capsule will be located in a new position in the Chemical Spill for each round. It will be positioned by random selection. The victim will not be placed on the Chemical Spill until the robot has commenced moving.
- 2.9.3 The Rescue Capsule will be moved and repositioned in an upright orientation only after a restart but not under any other circumstance (see 6.4.7).
- 2.9.4 Open Rescue Line: A Rescue Capsule contaminated by the chemical spill without a Victim inside will be represented by a standard 375 ml aluminium can, standing upright, painted matt black or wrapped with black tape. This capsule will be referred to as an empty capsule.
- 2.9.5 Rescue Capsules, with or without a Victim, will contain material such as rice bringing the weight of the Rescue Capsule to a maximum of 100 gm. A liquid will not be used to add weight to the can.



2.10 Game Zone

- 2.10.1 The area around the Preliminary Round or Head-to-Head Round will be designated as the Game Zone. Only officials, referees, timekeepers and the Robot Handler may enter the Game Zone.
- 2.10.2 Each team can have only one robot in the Game Zone.
- 2.10.3 Access to the Game Zone by participants prior to the start of the event will be allowed at the discretion of the RoboCup Junior Australia Rescue Coordinator or other relevant person.

3 Robot

3.1 Robot Configuration

- 3.1.1 Robot must be able to pass through the Doorway without moving it significantly from its original position. The robot must do this autonomously during the scoring run.
- 3.1.2 **Riley Rover Rescue and** Primary Rescue Line robots must not increase in size, extend or use a device intended to sweep the Victim. Robots must demonstrate a search algorithm to find the Rescue Capsule as specified in 1.1.
- 3.1.3 Secondary Rescue Line and Open Rescue Line robots must have a functioning and demonstrable mechanism with the potential to control AND rescue the Victim as specified in 1.1. There will be no points given for a round where this mechanism cannot be seen by the referees.
- 3.1.4 Any robot kit or building materials may be used, as long as the robot fits the specifications documented in these rules and as long as the design and construction are primarily and substantially the original work of the student(s). Commercial robot kits may be used but must be substantially modified by the student participants.
- 3.1.5 Robots should be well engineered and constructed. The robot should not fall apart during the game. If the robot has substantially failed mechanically, fallen apart (see 6.3.5) or is unable to complete the challenge, the robot will be deemed damaged and the Robot Handler will be asked to remove the robot from the field. The Robot Handler may choose to restart according to 6.4.7, otherwise the round is deemed to have ended.
- 3.1.6 A team will not be able to compete with a robot substantially the same as another team's robot.
- 3.1.7 A team will not be able to compete with a robot that is identical to another team's robot from previous years.
- 3.1.8 Robots that cause interference with other robots or damage event equipment will be disqualified.

3.2 Robot Control

- 3.2.1 Robots must be started/restarted manually by the Robot Handler.
- 3.2.2 Once started the robots must be autonomous in operation. If the robot has the capability for remote or any other wireless control (such as by Bluetooth, Wi-Fi or another form of wireless communication), the team must prove that they have disabled the capability for third party operation in some way. This could be by software, hardware or degree of human interaction. Robots that do not comply may face immediate disqualification from the event. Distributed control is allowed but must operate without human interaction after the robot has started the round.
- 3.2.3 Pre-mapping and/or any type of dead reckoning (i.e., configuring the robot's program based on predefined locations, tiles, obstacles, location of victim, number of victims etc. before game play) is prohibited.
- 3.2.4 The use of remote control of any kind is forbidden.



3.3 Inspection

- 3.3.1 Teams may be scrutinised to establish the ownership of robot design and programming.
- 3.3.2 The robot will be inspected by a panel of referees before/during or after the event to ensure that the robot adheres to all relevant rules.
- 3.3.3 It is the responsibility of teams to have their robot re-inspected if their robot is modified at any time during the event.

3.4 Violations

- 3.4.1 Any violations of the inspection rules will prevent the robot from competing in a round until modifications have been made to the robot to ensure compliance.
- 3.4.2 Modifications must be made within the time schedule of the events. Rounds will not be delayed due to late teams.
- 3.4.3 If a robot fails to meet all specifications (including modifications) the robot will be disqualified from that round (but not the event).
- 3.4.4 If it is determined that the work on the robot is not substantially the original work of the team members or the construction or programming of the robot be deemed not that of the team, the team will be referred to officials. Should the Rescue Coordinator (or other relevant person) on the advice of the officials then uphold the view of the scrutiniser, the team may be disqualified from the event.

4 Inspection

4.1 Electronic Submission

- 4.1.1 Before registration closes, prior to the event, each team must electronically submit their journal and program or source code to the event organisers via the event web site or as otherwise directed. **Teams can continue to work on their robot, programs and this journal after submission.**

4.2 Interviews

- 4.2.1 Teams may be required to attend a technical interview to explain the operation of their robot in order to verify that the design, construction and programming of the robot is the students' work. There are no set questions. If interviews are being conducted, either a schedule will be released, or teams will be advised to go for an interview throughout the event well in advance of the Head-to-Head Round.
- 4.2.2 Teams must bring their journals, logbooks or design diaries and a running laptop to their interview with their program open and be able to talk through the logic of the program with the interviewer. Screenshots of the program or source code are unacceptable.
- 4.2.3 Interviews are not scored and do not contribute to overall team score.
- 4.2.4 Team member(s) will be asked questions about their preparation efforts, and they may be requested to answer surveys and participate in videotaped interviews for research purposes.

4.3 Journal/Logbook

- 4.3.1 All teams must maintain a journal/logbook or design diary detailing the design, development and construction of the robot and its programs as part of the learning experience. The journal can be in the form of a written



document, PowerPoint presentation, website or blog, etc. Journals/Logbooks or Design Diaries are not scored and do not contribute to the team’s overall score but will be used to determine ownership of designs.

- 4.3.2 Construction of components (not freely or commercially available to all competitors) must be accompanied by full documentary proof that the developments were wholly the work of the students. This should be in the form of technical documentation showing all stages of design, development, testing and construction.
- 4.3.3 Failure to produce documentary proof of students’ work may result in the robot or custom component not being allowed to compete in the tournament.

4.4 Journal/Logbook Criteria

4.4.1 The following headings are a guide in the development of student journals. [These criteria are mapped to the Australian National Technologies Curriculum](#)

Team Name	
Team Members	List each member’s role
School or Organisation	
Problem Definition	Define and decompose the problem
Planning	Identify a number of possible solutions to meet the requirements and constraints
	Identify the roles of the team and the order of tasks
Solution Design	Design the user experience of a digital system
	Design algorithms and validate them.
Implementation	Implement modular programs, applying selected algorithms and data structures
Evaluation	Critically evaluate the developed solution.
Student Collaboration	Create innovative solutions for sharing your ideas and information.
	Plan and manage projects using an interactive and collaborative approach
Robot	Construction Photos
	Code

5 Teams

5.1 Definition

5.1.1 A team should have a minimum of 2 members and a maximum of 4 members.

An individual participant is permitted to compete in the Rescue Challenge at a RCJA Australian Open as an individual only once. To do so the individual must seek approval from the event organiser. If a team can only afford, or due to extenuating circumstances, cannot send more than one member to an event, then this is allowed as the Journal/Logbook or Design Diary will show that they have been part of a team.

5.1.1.1 Students will participate in only one of the three Rescue Line divisions: **Riley Rover Rescue**, Primary Rescue Line, Secondary Rescue Line or Open Rescue Line. [Teams can also compete in Rescue Maze.](#)

5.1.2 The qualification requirements for each Rescue Challenge division are:



- 5.1.2.1 **Riley Rover Rescue:** Open to students at an age that would typically be studying at either a primary or secondary provider. This is open to students who are new to robotics or attempting a new challenge such as creating a robot based on an Arduino or Raspberry Pi controller programmed with a text-based coding language. Students will only be allowed to enter at this level for one year.
- 5.1.2.2 **Primary Rescue Line:** Open to students at an age that would typically be studying at a recognised primary study provider. Team members can compete any number of times whilst they are enrolled at a recognised primary study provider.
- 5.1.2.3 **Secondary Rescue Line:** Open to all students at an age that would typically be studying at a recognised secondary study provider. Team members are only eligible to compete for a total of two years in this division after which they must participate in Open Rescue Line.
- 5.1.2.4 **Open Rescue Line:** Open to all students at an age that would typically be studying a recognised primary or secondary study provider.
- 5.1.3 For each round, one team member is to be nominated as the Robot Handler. Only the Robot Handler is permitted to enter the Game Zone and handle the robot during the round. All other team members must remain outside the Game Zone unless authorised by the Referee, Timekeeper, Official or other relevant person.
- 5.1.4 The Robot Handler is the only team member permitted to communicate directly with the Referees, Timekeeper and Officials.
- 5.1.5 No electronic devices may be used for one- or two-way communication between event participants within the Game Zone, or from outside the Game Zone or vice versa.

6 Game Play

Games will be organised into Preliminary Rounds, then a Head-to-Head Round.

6.1 Length of a Game

- 6.1.1 Organisers will ensure that the field design will be a suitable length for the time limit.
- 6.1.2 A robot will have a maximum time limit to complete the course. Time limits are:

Division	Game Length (sec)	Calibration Window
Riley Rover Rescue	120	Prior to the game clock starting
Primary Rescue Line	120	Prior to the game clock starting
Secondary Rescue Line	150	Prior to the game clock starting
Open Rescue Line	240	After starting the game clock

- 6.1.3 Time limits may be extended for the Head-to-head round. This is at the discretion of the Rescue Coordinator. Participants will be informed of the change prior to the running of the round.



6.2 Pre-Game

- 6.2.1 The Referee will ask the Robot Handler if they would like to nominate a Drop Zone. If the Robot Handler elects a Drop Zone, the tile will be marked with the Drop Zone Puck in one of the corners.
- 6.2.2 The Referee will ask the Robot Handler if they are happy with the course. After positive acknowledgement, the Robot Handler may place the robot on the course ready to start.
- 6.2.3 The robot must start from either the City Limits or from the nominated Drop Zone. The entire robot must be behind the join between the start tile and the next course tile.
- 6.2.4 The Referee will ask the Robot Handler if they are ready to start. The Robot Handler must indicate to the Referee they wish to commence the Rescue run.

6.3 Game Play

- 6.3.1 Once a team is ready to perform a scoring run, they must notify the Referee. The Referee will indicate to the Robot Handler that they may proceed. At this point the round begins and the Referee starts the game timer for the round.
- 6.3.2 **Open Rescue Line:** Calibration of the robot is only permitted once the timing of the round has begun.
- 6.3.3 Robots may move in any direction from the Drop Zone. The entire robot must be behind the join between the two tiles.
- 6.3.4 Once the round has begun, the robot is not permitted to leave the Game Zone for any reason.
- 6.3.5 Modifying a robot, once a round has begun, is prohibited until the run is over or a Restart is called (see 6.4.7). This includes adding, removing or remounting parts.
- 6.3.6 Any parts that have fallen off during a round, intentionally or otherwise, are to be left in the Game Zone and cannot be moved or removed by the Robot Handler until the run is over or a Restart is called (see 6.4.7).
- 6.3.7 The robot must follow the line completely to enter the Chemical Spill.
- 6.3.8 Once the robot has entered the Chemical Spill it is no longer required to follow the line. It may enter the Chemical Spill in any orientation in its efforts to rescue the Victim.
- 6.3.9 To rescue the Victim:
 - 6.3.9.1 **Riley Rover Rescue and Primary Rescue Line:** The Victim is considered rescued when the Rescue Capsule is completely outside the Chemical Spill.
 - 6.3.9.2 **Secondary Rescue Line:** Control of the Rescue Capsule means the Rescue Capsule will move with the robot no matter which direction the robot moves (forward, backwards or rotating in either direction.) The Victim is considered rescued when the Rescue Capsule is completely outside the Chemical Spill and has been released in an upright, top up orientation by the robot.
 - 6.3.9.3 **Open Rescue Line:** Control is defined as having lifted the Rescue Capsule to a height that will allow the Rescue Capsule to be placed on the platform and maintain the lift while the robot is moving. The Victim is considered rescued when the Rescue Capsule has been placed on the Evacuation Platform in an upright, top up orientation and has been released by the robot.



6.3.10 The round is considered complete when **any one or more of the below conditions has been reached:**

- 6.3.10.1 The maximum possible points for the round are achieved,
- 6.3.10.2 The game timer has run out,
- 6.3.10.3 The Robot Handler declares an end to the scoring run.

6.3.11 **It is the responsibility of the Robot Handler before exiting the Game Zone to double check with the referee that their team score has been entered correctly.**

6.4 Lack of Progress

6.4.1 A Lack of Progress occurs when **any one or more of the below conditions has been reached:**

- 6.4.1.1 The robot is touched by a human
- 6.4.1.2 The Robot Handler calls a Lack of Progress (for example, if the robot is about to fall and be damaged or the robot is malfunctioning)
- 6.4.1.3 The robot knocks over the Doorway or moves it significantly from the original position
- 6.4.1.4 The robot is stuck in the same place.
- 6.4.1.5 The robot moves completely out of the field
- 6.4.1.6 The robot exits the Chemical Spill in a direction other than via the 'Spill Access Point' or exits without attempting to rescue the Victim
- 6.4.1.7 The robot ceases to follow the line. Robots are not allowed to take shortcuts within a tile, the line shape must be substantially followed on that tile unless there is an obstacle on that tile that must be avoided (see 2.4.7), or the line is discontinuous (see 6.5.2).

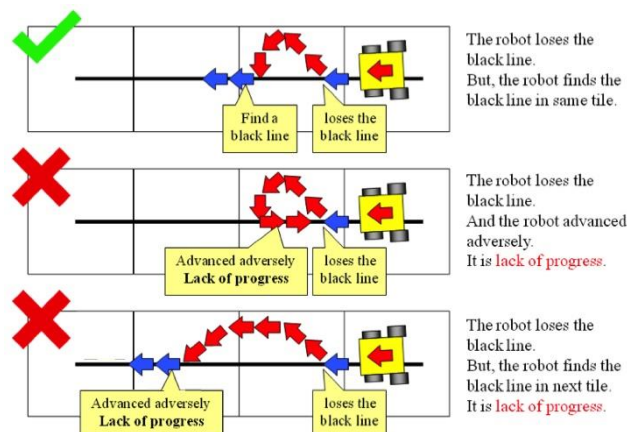

6.4.1.8 The robot fails to reacquire the line before exiting the tile.

6.4.2 A robot travelling towards, and then exits the field via the City Limits start tile, may re-start the course with no Lack of Progress penalty.

6.4.3 If a Lack of Progress occurs, the robot must be repositioned at one of the Start Tiles (see 2.8.1) and started.



- 6.4.4 Only the Robot Handler is allowed to start the robot.
- 6.4.5 There is no limit to the number of Resets due to lack of progress within a round.
- 6.4.6 The game clock will continue running during all Resets and Restarts.
- 6.4.7 A team may call for a Restart to their Scoring Run. This allows the team to change programs, change code, modify the robot and set a new Drop Zone.
Note: The clock does not reset and continues running.
Note: All points earned prior to the Restart are invalid and scoring begins again once the robot commences a new Scoring Run.
- 6.4.8 The Robot Handler may choose to make further attempts at the course to earn additional points available for completing tiles, obstacles, speed bumps, etc. that have not already been earned by calling a Lack of Progress and starting from a designated Start Tile (see 2.8.1).

6.5 Following the Line

- 6.5.1 Where there are multiple paths, the robot may take any path.
- 6.5.2 Where the line is discontinuous, and there is no continuous path through the tile, the robot may search for the recommencement of the line but must not completely leave the tile before re-finding the line.
- 6.5.3 A robot is considered to be following the line as long as some part of the robot is over the line while being viewed from directly above the robot by the referee.
- 6.5.4 Where a line exists, some portion of the line segment should be under the robot (see 6.4.1.7 and 6.4.1.8).

6.6 Scoring

- 6.6.1 Teams will be awarded 10 points for each line follow tile that their robot successfully negotiates. For example, robots reaching the fourth tile would have successfully negotiated three tiles and be awarded 30 points.
- 6.6.2 Teams will gain an extra **five** points for each intersection marker they correctly follow. For example, if a robot correctly follows both shortcut markers on the roundabout, it will be awarded 10 points for completing the line follow of the tile and 8 points (four plus four) for correctly following the two shortcut markers.
- 6.6.3 Rescue Teams will be awarded an additional 20 points for fully exiting the Chemical Spill via the Spill Access Point. The robot must reacquire the line and begin to line follow **after** successfully rescuing the Victim or attempting to rescue the Victim before the points are awarded.
- 6.6.4 **Scoring Summary:**

Action Completed	Points Scored
Tile	+10
Follow an intersections marker	+5
Execute a robot behavior triggered by a coloured marker or interaction with an element in the field.	+5



Action Completed	Points Scored
Bridge, See-Saw or equivalent	+5
Speed Bump	+5
Debris	+5
Obstacle	+10
Riley Rover Rescue and Rescue Line Primary – Rescue Victim	50 for Rescue
Rescue Line Secondary – Rescue Victim	50 for Control 50 for Rescue
Rescue Line Open – Rescue Victim	50 for Control 50 for Rescue
Rescue Line Open – Control or Rescue of an empty capsule	0
Exit the chemical spill via the spill access point and reacquire the line (this applies to Primary, Secondary and Open Rescue Line divisions)	20

6.6.5 Points will be awarded only once for successful completion of an element of the course.

6.6.6 In Primary Rescue, Secondary Rescue and Open Rescue, five points will be deducted from the score for each Lack of Progress, up to a maximum of 20 points deducted.

6.6.7 A Secondary or Open Rescue team that elects to end their scoring run before the round timer has run out will receive the maximum deduction of 20 Lack of Progress points.

6.6.7.1 Primary Rescue Line - no penalty

6.6.7.2 Secondary Rescue Line - 20 points

6.6.7.3 Open Rescue Line - 20 points

For example, a Secondary Rescue Line team has received two Lack of Progress deductions (10 points in total) and has now elected to end their scoring run before the round timer has run out. The team will receive a total Lack of Progress deduction of 20 points, not 30 points.

6.6.8 No team can end a round with a negative score. A score of zero will be awarded in this case.

6.7 Preliminary Rounds

6.7.1 A Scoring Run will be based on the sum of all points scored (see 6.6.4).

6.7.2 There may be multiple Preliminary Rounds, depending on the time constraints of the event.

The RCJA Australian Open will aim to hold a minimum of five Preliminary Rounds.



6.7.3 Each team will have one scoring run per round.

6.7.4 Officials at the event will determine the order and nature of how each round will be conducted. All teams must consult with the officials at the start of the event to be informed on how the Preliminary Rounds will be run.

6.7.5 After the Preliminary Rounds have been run, teams will be ranked according to their Cumulative Score. This will be calculated by the addition of the result of the Scoring Run from each round.

6.8 Finals

6.8.1 The first, second and third placed teams will be determined by the Head-to-Head Round.

6.8.2 There will (typically) be three teams in the Head-to-Head Round. The teams will be determined by selecting the top ranked teams from the Preliminary Rounds. Should there be more than three teams in the top three (due to tied scores), further playoff rounds may be run as a tie break. The scores for these rounds will only be used for the purpose of breaking the tied scores. It is also permissible for the number of teams in the Head-to-Head Round to vary (see 1.1.7).

6.8.3 The finalists will rotate through and attempt each of the courses in the Head-to-Head Round. The team with the highest cumulative score from courses completed in the Head-to-Head Round will be judged the winner. Second and third placings are also determined through ranking this cumulative score.

6.9 Special Circumstances

6.9.1 Specific modifications to the rules to allow for special circumstances, such as unforeseen problems and/or capabilities of a team's robots, may be agreed to at the time of the tournament, provided a majority of the teams agree.

7 Challenge Track

7.1 Challenge Description

7.1.1 Some courses in **Primary, Secondary and Open Rescue Line** will contain a Challenge Tile that must be completed to obtain full points for that round.

7.1.2 The Challenge Tile will be independent of the pathway to the Chemical Spill.

7.1.3 The Challenge Tile will contain an additional challenge that is not part of the Official RoboCup Junior Australia Practice Rescue Mat or the 300mm Tiles that can be obtained from Modern Teaching Aids (Platinum National Sponsor).

7.1.4 Three tiles prior to the spill a tile will be placed that will change the direction of the course when the robot is making its way from the Chemical Spill following an attempted or completed Rescue. This will allow access to the Challenge Tile.

7.1.5 In some cases, a tile may need to be turned in order to access the Challenge Tile. This will only be turned by the Referee after the robot has attempted or completed the rescue.

7.1.6 If the robot handler does not wish the robot to attempt the Challenge Tile after exiting the Chemical Spill but would rather have the robot travel back along the course to attempt tiles that have not been successfully completed, the robot handler must inform the referee.



- 7.1.7 The robot must provide an indication that it has completed the Challenge Tile (e.g., flashing on-board lights, sound is not recommended since it may not be heard over the noise at the event venue). The robot handler must inform the Referee of the indicating signal.
- 7.1.8 A selection of Challenge Tiles from which the Challenge Tile(s) used will be chosen will be published by the end of the first week of August on the RCJA Rescue Webpage.

7.2 Scoring the Challenge

- 7.2.1 The Challenge Track is only to be attempted after attempting or completing a rescue.
- 7.2.2 Points will be awarded for all course tiles completed after exiting the spill that are part of the Challenge Track (see 6.6.4).
- 7.2.3 If a robot accidentally enters the Challenge Track prior to attempting or completing a rescue, the robot will be considered to have lost the line and Lack of Progress will be called.
- 7.2.4 Successful completion of the Challenge Tile is worth 50 points.



8 Conflict Resolution

8.1 Referee and Referee Assistant

- 8.1.1 All decisions during game play are made by the referee or the referee assistant who are in charge of the arena, persons and objects surrounding them.
- 8.1.2 During game play, the decisions made by the referee and/or the referee assistant are final.
- 8.1.3 At conclusion of game play, the referee will ask the Robot Handler to sign the score sheet. The Robot Handler should be given a maximum of 1 minute to review the score sheet and sign it. By signing it, the Robot Handler accepts the final score on behalf of the entire team; in case of further clarification, the Robot Handler should write their comments in the score sheet and sign it.

8.2 Rule Clarification

- 8.2.1 If any rule clarification is needed, contact the RoboCup Junior Australia Rescue Technical Committee.
- 8.2.2 If necessary, even during a tournament, a rule clarification may be made by members of the RoboCup Junior Australia Rescue Technical Committee and Organising Committee.

8.3 Special Circumstances

- 8.3.1 If special circumstances, such as unforeseen problems or capabilities of a robot occur, rules may be modified by the RoboCup Junior Australia Rescue Challenge Coordinator (or other relevant person) in conjunction with available Technical Committee and Organising Committee members, if necessary, even during an event.
- 8.3.2 If any of the team members/mentors do not show up to the team meetings to discuss the problems and the resulting rule modifications described at 8.3.1, it will be considered as an agreement.

9 Code of Conduct

9.1 Spirit

- 9.1.1 It is expected that all participants (students and mentors alike) will respect the aims and ideals of RoboCup Junior as set out in our mission statement.
- 9.1.2 The Volunteers, Referees and Officials will act within the spirit of the event to ensure the event is competitive, fair and most importantly fun.
- 9.1.3 It is not whether you win or lose, but how much you learn that counts!

9.2 Fair Play

- 9.2.1 Robots that cause deliberate or repeated damage to the arena will be disqualified.
- 9.2.2 Humans that cause deliberate interference with robots or damage to the arena will be disqualified.
- 9.2.3 It is expected that the aim of all teams is to participate fairly.

9.3 Behaviour

- 9.3.1 Participants should be mindful of other people and their robots when moving around the tournament venue.



- 9.3.2 Participants are not allowed to enter setup areas of other leagues or other teams, unless explicitly invited to do so by team members.
- 9.3.3 Teams will be responsible for checking update information (schedules, meetings, announcements, etc.) during the event. Update information will be provided on notice boards in the venue and (if possible) on the local event website and/or the RoboCup or RoboCup Junior websites.
- 9.3.4 Participants who misbehave may be asked to leave the building and risk being disqualified from the tournament.
- 9.3.5 These rules will be enforced at the discretion of the referees, officials, tournament organizers and local law enforcement authorities.

9.4 Mentors

- 9.4.1 Adults (mentors, teachers, parents, chaperons, translators and other adult team members) are not allowed in the student work area.
- 9.4.2 Sufficient seating will be supplied for mentors to remain in a supervisory capacity close to the student work area.
- 9.4.3 Mentors are not permitted to repair robots or be involved in programming of their team's robots.
- 9.4.4 Mentor interference with robots or referee decisions will result in a warning in the first instance. If this recurs, the team will risk being disqualified.
- 9.4.5 Robots must be mainly students' own work. Any robot that appears to be identical to another robot may be prompted for re-inspection.

9.5 Ethics and Integrity

- 9.5.1 Fraud and misconduct are not condoned. Fraudulent acts may include the following:
 - 9.5.1.1 Mentors working on the software or hardware of students' robot(s) during the event.
 - 9.5.1.2 "Higher League Groups" and/or more advanced groups of students may provide advice, but should not do the work for "Lower League Groups".

For example, a secondary group helped to fix its peer primary group's work, software or hardware prior to and/or during the event. This risks disqualification of the primary group and may also risk disqualification for the secondary group (see 9.4.3 and 9.4.5), as the secondary group is deemed to be Mentor(s).
- 9.5.2 RoboCup Junior Australia reserves the right to revoke an award if fraudulent behaviour can be proven after the event.
- 9.5.3 If it is clear that a mentor intentionally violates the code of conduct, and repeatedly modifies and works on the students' robot(s) during the event, the mentor will be banned(s) from future participation in RoboCup Junior events.
- 9.5.4 Teams that violate the code of conduct can be disqualified from the tournament. It is also possible to disqualify only a single team member from further participation in the tournament.
- 9.5.5 In less severe cases of violations of the code of conduct, a team will be given a warning. In severe or repeated cases of violations of the code of conduct, a team can be disqualified immediately without a warning.



9.6 Sharing

- 9.6.1 The spirit of world RoboCup events is that any technological and curricular developments should be shared with other participants after the tournament.
- 9.6.2 Any developments may be published on the RoboCup Junior website after the event.
- 9.6.3 Participants are strongly encouraged to ask questions to their fellow competitors to foster a culture of curiosity and exploration in the fields of science and technology.
- 9.6.4 This furthers the mission of RoboCup Junior as an educational initiative.